

- In addition to routine checks for each use, PPE should regularly undergo a detailed inspection by a competent person. Petzl recommends an inspection every 12 months and after any exceptional event in the life of the product.
 - PPE inspection should be conducted with the manufacturer's Instructions for Use.
- Download the Instructions at [PETZL.COM](https://www.petzl.com)



PROGRESS-CAPTURE PULLEY

1. Known product history

Any PPE showing questionable degradation should be quarantined, pending a detailed inspection.

The user should:

- Provide precise information on the usage conditions.
- Report any exceptional event regarding their PPE.
 (Examples: fall or fall arrest, use or storage at extreme temperatures, modification outside manufacturer's facilities)

2. Preliminary observations

Verify the presence and legibility of the serial number and the CE mark.

Note: the serial number code on our products is evolving. Two types of code will coexist. See below for details on each serial number code.

Code A:

00 000 AA 0000

<p>Year of manufacture</p> <p>Day of manufacture</p> <p>Name of Inspector</p> <p>Incrementation</p>	
-----------------------------------------------------------------------------------------------------	-------------------------------------------------------------------------------------

Code B:

00 A 0000000 000

<p>Year of manufacture</p> <p>Month of manufacture</p> <p>Batch number</p> <p>Incrementation</p>	
--------------------------------------------------------------------------------------------------	---------------------------------------------------------------------------------------

Verify that the product lifespan has not been exceeded.

Compare with a new product to verify there are no modifications or missing parts.

Note: For the B coding, the month of manufacturing is indicated by a letter. A corresponds to January, B to February, C to March, and so on.

3. Checking the condition of the side plates

- Check the condition of the moving side plates (deformation, cracks, marks, wear, corrosion).

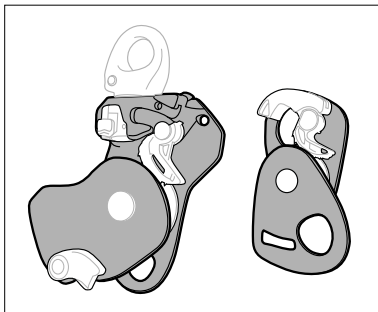

- Check the condition of the attachment hole (deformation, cracks, marks, wear, corrosion).

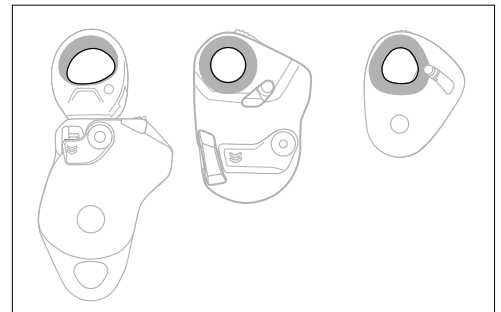

- If applicable, check the condition of the auxiliary attachment hole (deformation, cracks, marks, wear, corrosion).

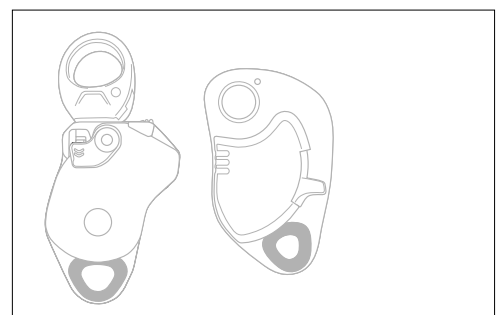

- Check the condition of the rivets (deformation, cracks, marks, wear, corrosion, lack of play).

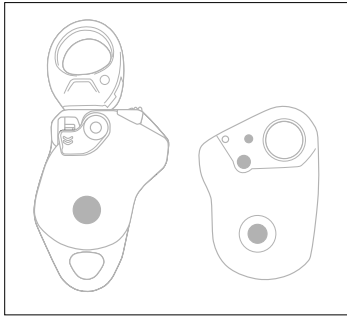

- Verify that the side plates rotate properly.

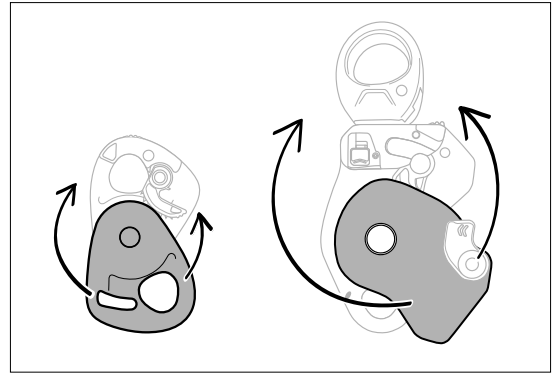

4. Checking the side plates' opening and locking systems

- Check the condition and function of the locking system (deformation, cracks, marks, wear, dirt, effectiveness of the return spring(s)).

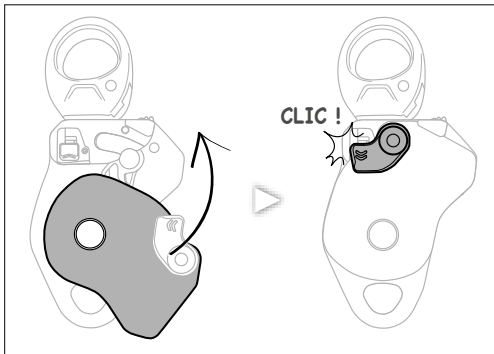
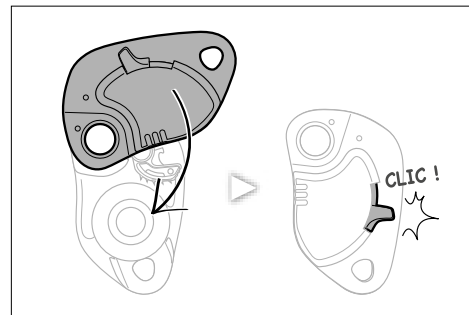
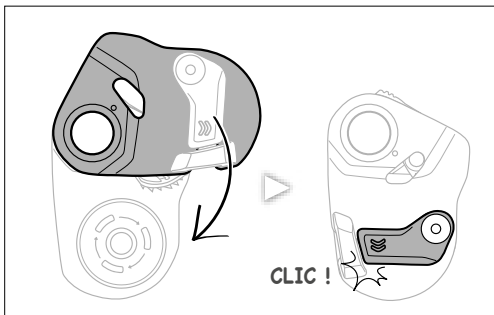

5. Checking the cam

- Check the condition of the gate (deformation, cracks, marks, wear, corrosion, absence of foreign bodies). Check that all teeth are present and check their state of wear. The teeth must not be dirty. If necessary, clean them with a brush.

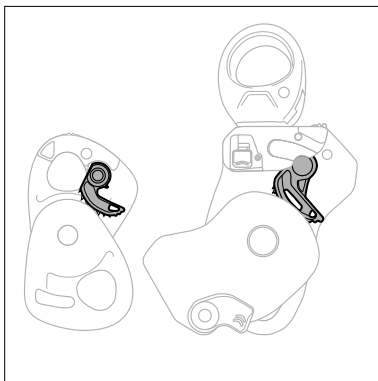

- Check the cam's rotation and the effectiveness of the return spring.

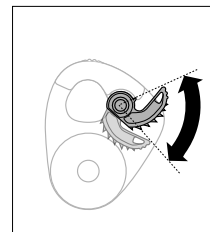

- Verify that the cam catch is working properly.

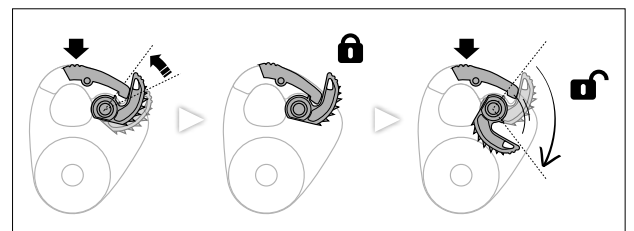

6. Checking the sheave

- Check the condition of the sheave (deformation, cracks, marks, wear, corrosion, absence of foreign bodies).

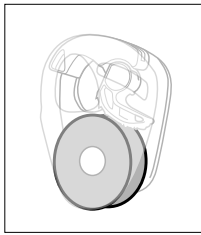

- Verify that the sheave turns freely in both directions.

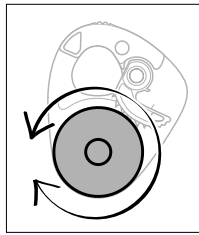

7. Function check

- Install your pulley on an anchor and install a compatible rope around the sheave.
- With the cam deactivated, circulate the rope in both directions.

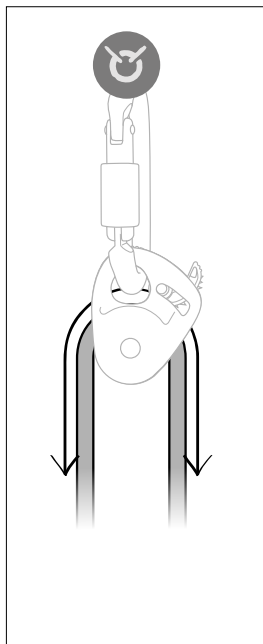

- With the cam activated, make sure the rope circulates in one direction and blocks in the other direction.

