

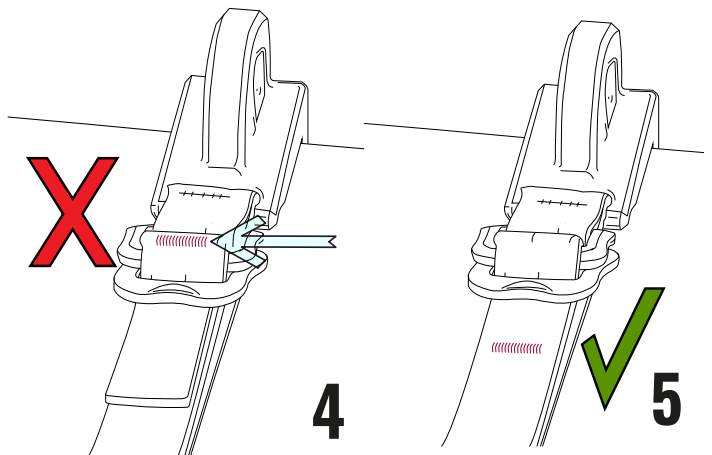

**M60 - URU
Beam Clamp**
Patent Pending
Made in Canada from
a solid block of Aluminium

Markings and/or symbols

EYOLF: name of the manufacturer
 M60 URU Beam Clamp: prod. code & name
 MBS: Minimum Breaking Strength
 11-2020: month and year of manufacturing
 Batch 10174 (example): serial number
 Pictogram that advises to read instructions
 CE which stands for "Conformité Européenne"
 ("European Conformity")
 2927: Notified Body number that regularly
 checks the production of this PPE according to
 module D ((EU) Regulation 2016/425)
 EN 795 is the European standard to which the
 product is certified.

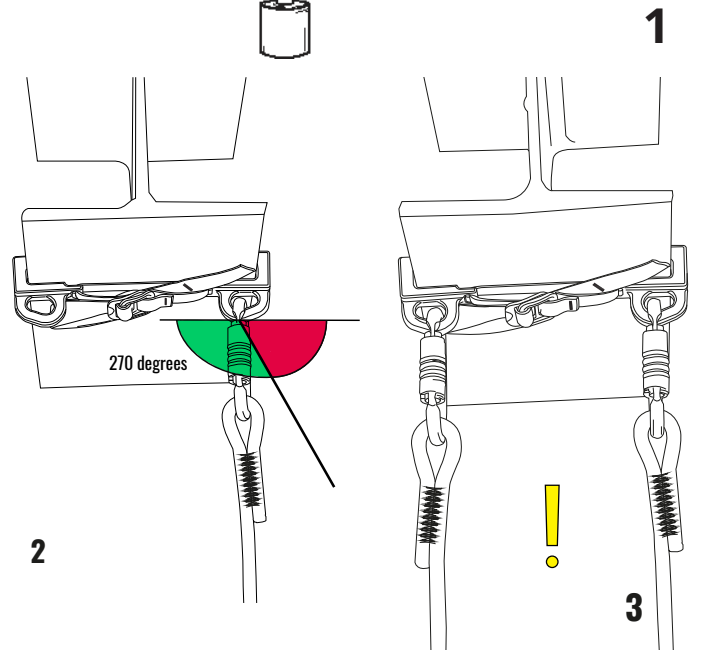
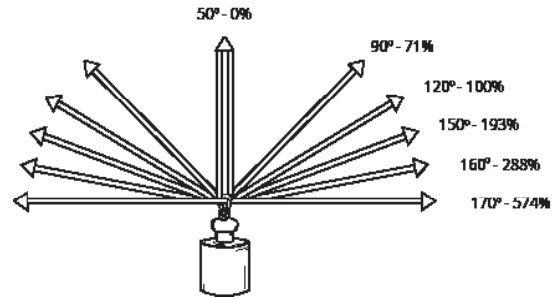
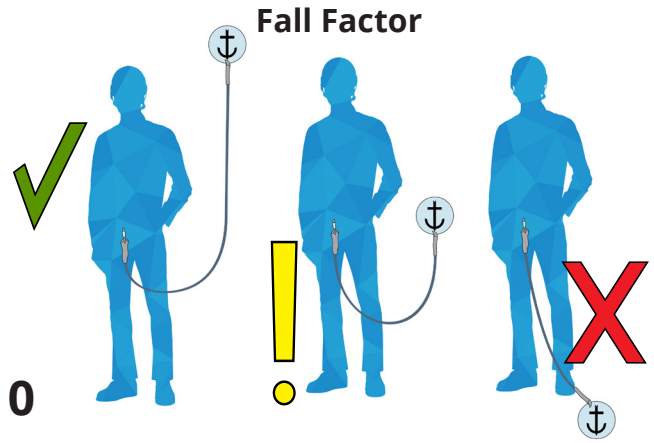

Maintenance

Storage

Important info

Inspection & repairs

Questions

Range beam clamps:
 Flange thickness max: Reg.
 13mm / 1/2" - Large 24mm / 1"
 Flange width: 15cm / 6" upto
 30cm / 12"

Notified body for EU type examination:
CZU (1015), Module B.
 Strojírenský zkušební ústav, s.p. Tovární 89/5, 466 21 Jablonec
 nad Nisou, Czech Republic

Notified body controlling the manufacturing of this PPE, mod-
 ule D:
QUINTIN CERTIFICATIONS (2927) - Module D
 825 route de Romans
 38160 Saint Antoine l'Abbaye - France

The provisions of EN 795:2012 deal with the basic require-
 ments and provisions of Regulation (EU) 2016/425.

The EU declaration of conformity can be found at:
www.eyolf.ca

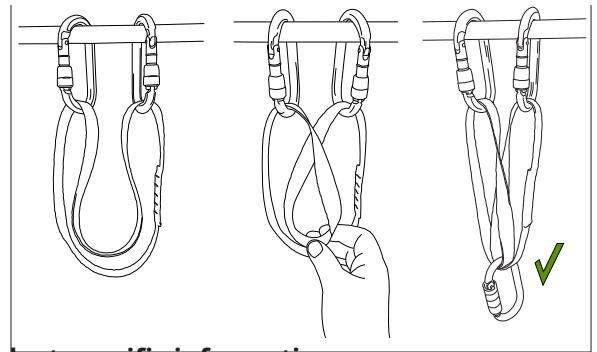
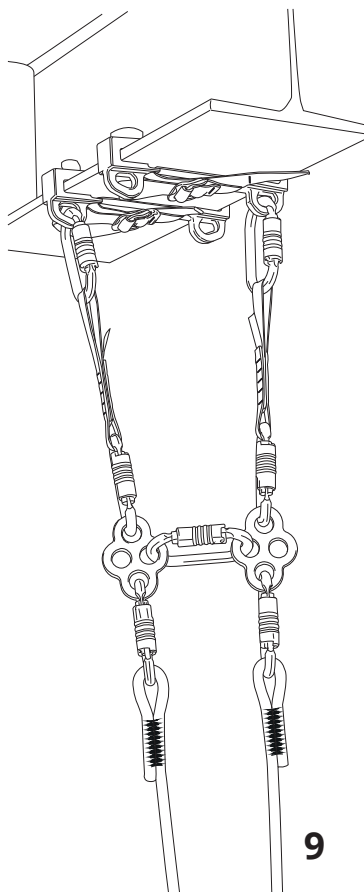
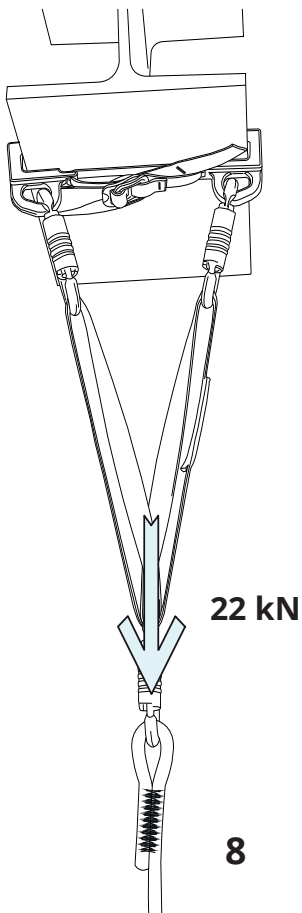
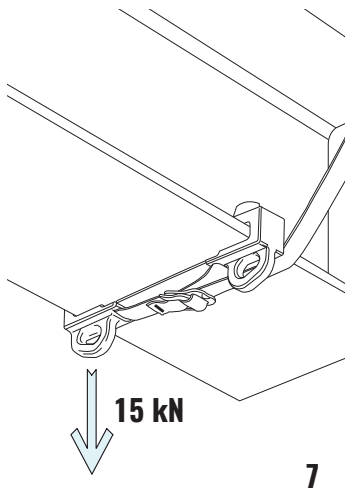
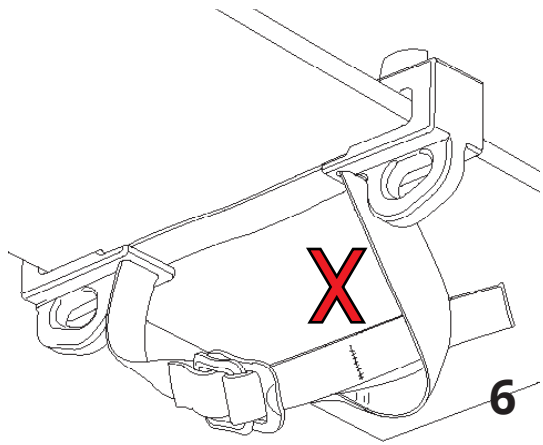

10

Product specific information

The URU Beam Clamp has been designed to create anchor points on steel structural beams. They are designed and tested to work with fall protection systems and specifically developed for rope access.

Diagram 1: Rigging angles, sharing the two anchor eyes can help with increasing security and strength. As long as you stay within 120 degrees. Beyond you will be multiplying your rating, see diagram.

Diagram 2: Rigging from the beam clamp, stay within the indicated 270 degrees.

Diagram 3: The beam clamp is one system. This is important for rope access rigging as you will need two independent redundant systems.

Diagram 4 & 5: The strap going through the buckle doesn't have a hemped end. Instead we have a red bartack to indicate to not go past the buckle with this red stitched line. Leave the 5 cm - 2 inch of strap at all times.

Diagram 6: Do not leave the strap loose and only rely on the screw bolts to secur the beam clamp onto the beam. The strap however is mandatory at all times and tail should be tight off when possible to prevent it from loosening.

Diagram 7: A single eye is rated for 15 kN - 3500 lb. MBS.

Diagram 8: Combining two anchor eyes together you get a MBS of 22 kN - 5000 lb.

Diagram 9: The beam clamp is one system. This is important for rope access rigging as you will need two independent redundant systems as is shown in this drawing.

Diagram 10: When rigging slings as shown in diagram 9 make sure you twist the sling to prevent the carabiner on the rope side from not being attached if one of the sides would be released.



Instructions for use – General information

General requirements for instructions for use, maintenance, periodic examination, repair, marking and packaging as per EN 365:2004

Thank you for using an Eyolf product. We have done everything possible to ensure that the information provided in this manual is accurate at the time of publication. However, we do not guarantee that this information will remain up to date, as many products and techniques change over time.

The information in the manuals must be understood.

Read the manual and keep it - Keep the user instructions/information accessible as a permanent record on- and off-site. Keep a copy of the manual.

Mountaineering, climbing, caving, working at height and other related activities are inherent dangerous due to outside factors and hidden risks. Not understanding, taking precautions and eliminating these risks can lead to serious injuries and death.

The manufacturer cannot be held liable if the equipment has been abused and/or misused. You are responsible for your own actions and decisions.

Contact us if you have any questions or concerns.

Warning

Medical condition

It should be understood that working at height and the use of equipment to do so, involves a certain amount of physical and mental exertion. Certain medical conditions are a definite contra-indication to the safe use of the equipment and working at height.

Training

Training and assessment of competency are essential before use of this product. Users must be aware of the limitations, precautions and the dangers of misuse.

Risk assessment - rescue plan

A risk assessment and a quick response rescue plan should be in place prior to any activities at height. Have a suitable rescue plan in place!

Repairs

Do not make any alternations or additions to the product without the manufacturer's prior written consent. Repairs shall only be carried out in accordance with manufacturer's procedures. Without consent any repair or alterations should be done by the manufacturer.

Limitations

The equipment has been tested for specific use, do not use the equipment outside its limitations without the consent of the manufacturer.

PPE

PPE stands for Personal Protective Equipment and in case of this product this means it should be provided to an individual user.

Strengths

Strengths quoted are when the product is tested new and are in accordance with the manufacturers test methods or to the appropriate standard. Any weights and measurements are approximate.

Compatibility

When combining products together make sure that they can be safely used together. Some parts of one product might interfere with the strength and/or safety aspects of the other product. Compatibility needs to be checked prior to use.

Minimize a fall at all times, check your fall factors and the equipment you're using to see if it can survive the impact.

Use in extreme environment

Use of any PPE in extreme environments can be dangerous. It is important to do appropriate testing before the use of our products in environments such as extreme cold or high temperatures (working temperatures are -30 degrees up to 60 degree Celsius), chemicals, dust, sand and other foreign materials, electrical power, grinding and chafing should be avoided, if you have any questions contact us and we can help you determine the effects.

Inspections for periodic examinations

An examination should be carried out before the product is put into service.

Periodic examinations should take place at least once a year, taking into account factors such as legislation, equipment type, frequency of use, and environmental conditions.

A periodic exam should be carried out by a competent person.

For complex items such as self retractable lifelines please contact us for further details.

Before each use visually inspect to ensure the product is in serviceable condition and operates correctly. If any compromises are found do not use the product and retire it.

If the product has been used to arrest a fall, withdrawn from use immediately! Do not use again until, in writing, a competent person says it is acceptable for use.

A pre-use check by the user may not be applicable if the user is under supervision of a competent person or in the case it is used for emergency use which have been pre-packed or sealed by a competent person.

When carrying out an inspection pay attention to the following items:

Check the label / marking (visible, legible, age)

Check webbing (cuts, burns, wear, chemical marks, crushed, other damage)

Check stitching (cut, worn, coloured or disordered threads)

Check attachment points (deformation, cracks, wear, corrosion, marks)

Check O-ring and connectors (deformation, cracks, wear, corrosion, marks)

Check compatibility of connector

Check condition of protective components

Safety of users depends upon the continued efficiency and durability of the equipment.

Transportation

Keep your equipment in a bag, such as our nylon or vinyl rope and/or equipment bags, during transportation.

Lifespan

This is difficult to estimate but we advise as follows: Do not use more than ten years after the date of manufacture. Assuming you have used the correct storage, the working life can vary from a ten-year span to a single use in extreme circumstances (e.g. highly chemical environment, serious fall, etc.). UV light including sunlight will reduce the working life.

Anchoring

Any anchorage used should be able to withstand a minimum force of 12Kn.

Do not create slack in the system and avoid any pendulum effect / swing during a fall.

Ideally the user should be attached to the anchor as vertically as possible

When connecting to an anchor device or structure use a suitable form of connector complying with EN 362, either with a shock absorber, complying with EN 355, a lanyard, complying with EN 354 or sling and carabiners depending on the situation you are in. Follow the standard EN 795 for anchoring.

Harness Connection Point

Connect the lanyard to the harness preferably to the sternal attachment point. When not possible attaching to the ventral attachment point is allowed as long as falls are impossible or there is a proper energy absorbance in the system, such as a dynamic rope system.

For fall arrest equipment, such as adding an energy absorber to the lanyard the right connection point is the Sternal or Dorsal attachment point, indicated with the letter A on a full body harness complying with EN 361.

The full body harness is the only type of harness suitable for being used in a fall arrest system.

Fall clearance

It is important to keep in mind that the flight path is clear from any obstacles when using a fall arresting system. It is essential for safety to verify the free space required beneath the user at the workplace before each occasion of use, so that, in the case of a fall, there will be no collision with the ground.

Calculating the total fall clearance

The fall clearance is the distance required to safely arrest a fall with an energy absorber. It is the distance from the anchor to the ground.

Step 1 – calculate the Free Fall (F)

Step 2 – determine from the label how much the shock absorber deploys (D)

Step 3 – determine the stretch of the harness (H)

Step 4 - add a safety factor of 2m (S)

Step 5 - add all figures together to get the clearance (C)

$$C=F+D+H+S$$

Maintenance

Always keep the product clean and dry. Any excess moisture should be removed with a clean, dry cloth and then allowed to dry naturally in a warm room away from direct heat.

4.3 a) Rinse in clean cold water. If still soiled wash in clean warm water (max. 40°C) with a soft detergent (within pH range of 5.5 to 8.5). Rinse properly in clean cold water and if needed to disinfect use a solution of water with alcohol. Do not use bleach!

Follow these instructions; if in doubt about the disinfecting method please contact us for further details.

Lubrication (if relevant)

When lubrication is needed a silicon-based oil can be used. Wipe off any excess and protect any webbing or rope from being sprayed.

Storage

After cleaning, store unpacked in a cool, dry, and dark place away from direct sunlight, as UV will cause damage to the webbing over time, excessive heat sources, sharp edges, vibration or other possible causes of damage. Do not store when wet or in a damp area >70%. If a long shelf life is required it is advisable to store in a moisture proof package, like a polyethylene bag.

Supervision

Under certain circumstances where a person is temporarily using a PPE against falling a competent and/or trained person could supervise the user.

Country of destination

It is essential for the safety of the user that if the product is re-sold outside the original country of destination the reseller shall provide instruction for use, for maintenance, for periodic examination and for repair in the language of the country in which the product is to be used.

EN 795:2012 Type B – Beam Anchor

One person

The anchor device is only to be used for one person only under normal working conditions.

Maximum Arrest Force - 6kN

When the anchor device is used as part of a fall arrest system, the user shall be equipped with a means of limiting the maximum dynamic forces exerted on the user during the arrest of a fall, to a maximum of 6kN.

Maximum load

The maximum load that could be transmitted in service from the anchor device to the structure and the directions of loading relevant to the type of fixing and structure are set by the type of usage and work load limit applicable to the situation of use.

Maximum deflection

Under normal loading (WLL 150 kg - 330 lb) there should not be any deflection with regards to the beam clamp.

Guidance on usage

If any I-beam is unstable (e.g. rust, too much paint, bird dropping, vegetation, ice, etc.), do not use this product.

PPE

The beam clamp are only to be used as PPE (Personal Protective Equipment) as part of a fall protection system and cannot be used for lifting and rigging.

Read the manual and keep it

Keep the user instructions/information accessible as a permanent record on- and off-site. Keep a copy of the manual with the product at all times.

Warranty

Equipment offered by Eyolf Inc. are warranted against factory defects in workmanship and materials for a period of three years from date of installation or use by the owner, provided that this period shall not exceed three years from the date of manufacturing (see label on product). Upon notice in writing, Eyolf Inc. will promptly repair or replace all defective items. Eyolf Inc. reserves the right to elect to have any defective item returned to its plant for inspection before making a repair or replacement. This warranty does not cover equipment damages resulting from abuse, damage in transit, or other damage beyond the control of Eyolf Inc. This warranty applies only to the original purchaser and is only one of applicable to Eyolf products, and is lieu of all other warranties, expressed or implied.



Owner: Address:

Product:
Model:
Serial #:
DoM:
Date of Purchase:
First use:
Eyolf Inc. Tel: +1 519 787 1581 PO Box 418 Email: info@eyolf.ca Fergus On N1M 3E2 Canada

YEAR 1	YEAR 4	YEAR 7	YEAR 9
INSPECTION RECORD DATE: RESULT: DATE NEXT INSPECTION: INSPECTOR SIGNATURE:	INSPECTION RECORD DATE: RESULT: DATE NEXT INSPECTION: INSPECTOR SIGNATURE:	INSPECTION RECORD DATE: RESULT: DATE NEXT INSPECTION: INSPECTOR SIGNATURE:	INSPECTION RECORD DATE: RESULT: DATE NEXT INSPECTION: INSPECTOR SIGNATURE:
YEAR 2	YEAR 5	YEAR 8	YEAR 10
INSPECTION RECORD DATE: RESULT: DATE NEXT INSPECTION: INSPECTOR SIGNATURE:	INSPECTION RECORD DATE: RESULT: DATE NEXT INSPECTION: INSPECTOR SIGNATURE:	INSPECTION RECORD DATE: RESULT: DATE NEXT INSPECTION: INSPECTOR SIGNATURE:	INSPECTION RECORD DATE: RESULT: DATE NEXT INSPECTION: INSPECTOR SIGNATURE:
YEAR 3	YEAR 6	Reason for entry inspection or repair	
INSPECTION RECORD DATE: RESULT: DATE NEXT INSPECTION: INSPECTOR SIGNATURE:	INSPECTION RECORD DATE: RESULT: DATE NEXT INSPECTION: INSPECTOR SIGNATURE:	Defects noted, repairs carried out and other information:	

Eyolf Inc.
191 Gregson Court
Fergus ON
N1M2W8 Canada
info@eyolf.ca
+1 519 787 1581

Eyolf Benelux
Zinkstraat 24 – unit C2261
4823AD Breda
The Netherlands
info@eyolf.nl