

OPERATION AND INSTRUCTION MANUAL

ROLLER SLING

Model: A114002, A114003, A114006



WARNING: ALL USERS OF THIS EQUIPMENT MUST READ AND UNDERSTAND ALL INSTRUCTIONS. FAILURE TO DO SO MAY RESULT IN SERIOUS INJURY OR DEATH. USERS SHOULD BE FAMILIAR WITH PERTINENT REGULATIONS GOVERNING THIS EQUIPMENT. ALL USERS OF THIS PRODUCT MUST BE PROPERLY INSTRUCTED ON HOW TO USE THE DEVICE. AVOID CONTACT WITH PHYSICAL HAZARDS (THERMAL, CHEMICAL, ELECTRICAL, ETC.). MAKE ONLY COMPATIBLE CONNECTIONS.

Read This Instruction Manual Carefully Before Using This Equipment.

User Instructions must always be available to the user and are not to be removed except by the user of this equipment.

For proper use, see supervisor, User Instructions, or contact the manufacturer. Werner Co. can supply additional information on request.



Compliant fall protection and emergency rescue systems help prevent serious injury during fall arrest. Users and purchasers of this equipment must read and understand the User Instructions provided for correct use and care of this product. All users of this equipment must understand the instructions, operation, limitations and consequences of improper use of this equipment and be properly trained prior to use per OSHA 29 CFR 1910.30 and 1926.503 or applicable local standards. The local competent person must keep these instructions, make them available to users, and require their use.

Misuse or failure to follow warnings and instructions may result in serious personal injury or death.

PURPOSE

The A114002, A114003, A114006 are anchorage connectors designed to function as an interface between the anchorage and a fall arrest, work positioning, rope access, or rescue system for the purpose of coupling the system to the anchorage. Any references to "anchorage connector" in this manual include, and apply to, the A114002, A114003, A114006.

USE INSTRUCTIONS

1. A user must be of sound mind and body to properly and safely use this equipment in normal and emergency situations.
2. Before using a personal fall arrest system, user must be trained in accordance with the requirements of OSHA 29 CFR 1910.30 and 1926.503 in the safe use of the system and its components.
3. Use only with ANSI/OSHA compliant personal fall arrest or restraint systems. The anchorage must have the strength capable of supporting a static load, applied in the directions permitted by the system, of at least 5,000-lbf (22kN) in the absence of certification.
4. The user shall be equipped with a means of limiting the maximum dynamic forces exerted on the user during the arrest of a fall to a maximum of 8 kN (1800-lbf).
5. Use of this product must be approved by an engineer or other qualified person to be compatible with any and all structural & operational characteristics of the selected installation location and system to be connected to this anchorage connector.
6. The anchorage connector must be inspected prior to each use for wear, damage, and other deterioration. If defective components are found, the anchorage connector must be immediately removed from service in accordance with the requirements of OSHA 29 CFR 1910.140 and 1926.502.
7. The anchorage connector should be positioned in such a way that minimizes the potential for falls and the potential fall distance during use. The complete fall arrest system must be planned (including all components, calculating fall clearance, and swing fall) before using.
8. A rescue plan, and the means at hand to implement it, must be in place that provides the prompt rescue of users in the event of a fall, or assures that users are able to rescue themselves.
9. After a fall occurs, the anchorage connector must be removed from service and destroyed immediately.

USE LIMITATIONS: This anchorage connector has been tested in compliance with the requirements of ANSI/ASSE Z359.7. Compliance testing covers only the hardware and does not extend to the anchorage and substrate to which the anchorage connector is attached. The anchorage connector must not be used outside its limitations, or for any purpose other than that for which it is intended. If this anchorage connector is used differently from these instructions it must be designed, installed, and used under the supervision of an engineer according to ANSI Z359.6 and local building codes as applicable.

1. The anchorage connector is designed for single user.
2. The anchorage connector may only be loaded in acceptable directions shown under CONFIGURATIONS.
3. The anchorage connector is designed to be used in temperatures ranging from -40°F to +130°F (-40°C to +54°C).
4. Do not expose the anchorage connector to chemicals or harsh solutions which may have a harmful effect.
5. Do not alter or modify this product in any way.
6. Caution must be taken when using any component of a fall arrest, work positioning, rope access, or rescue system near moving machinery, electrical hazards, sharp edges, or abrasive surfaces, as contact may cause equipment failure, personal injury, or death.
7. Do not use/install equipment without proper training by a "competent person" as defined by OSHA 29 CFR 1926.32(f).
8. Do not remove the labeling from this product.
9. Additional requirements and limitations may apply depending on anchorage type and fastening option utilized for installation. All placements must be approved by an engineer or other qualified person.
10. This anchorage connector should not be used as part of a horizontal lifeline system that has not been designed and/or approved to be used with 5,000-lbf (22kN) anchorage connectors.
11. The anchorage connector should only be used for personal fall arrest and not for lifting equipment.
12. If attaching the anchorage connector to the support structure by methods other than instructed, the attachment must be certified by a qualified person to meet the requirements of the system that will connect to the anchorage connector.

COMPATIBILITY LIMITATIONS

Anchorage connectors must only be coupled to compatible connectors. OSHA 29 CFR 1926.502 and 1910.140 prohibits snaphooks from being engaged to certain objects unless two requirements are met: it must be a locking type snaphook, and it must be "designed for" making such a connection. "Designed for" means that the manufacturer of the snaphook specifically designed the snaphook to be used to connect to the equipment listed. The following connections must be avoided, because they can result in rollout* when a nonlocking snaphook is used:

- Direct connection of a snaphook to horizontal lifeline.
- Two (or more) snaphooks connected to one D-ring.
- Two snaphooks connected to each other.
- A snaphook connected back on its integral lanyard.
- A snaphook connected to a webbing loop or webbing lanyard.
- Improper dimensions of the D-ring, rebar, or other connection point in relation to the snaphook dimensions that would allow the snaphook keeper to be depressed by a turning motion of the snaphook.

***Rollout: A process by which a snaphook or carabiner unintentionally disengages from another connector or object to which it is coupled. (ANSI Z359.0-2007)**

Model: Roller Sling

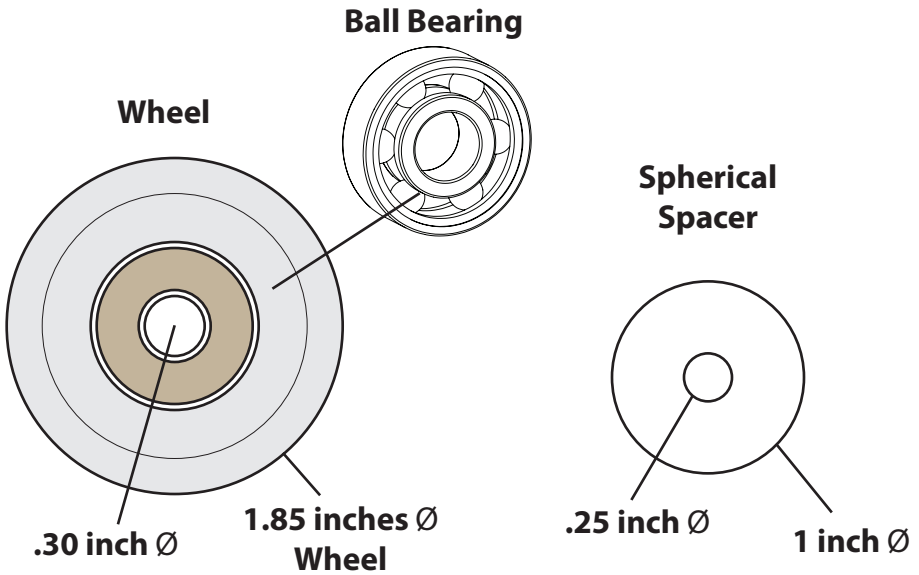
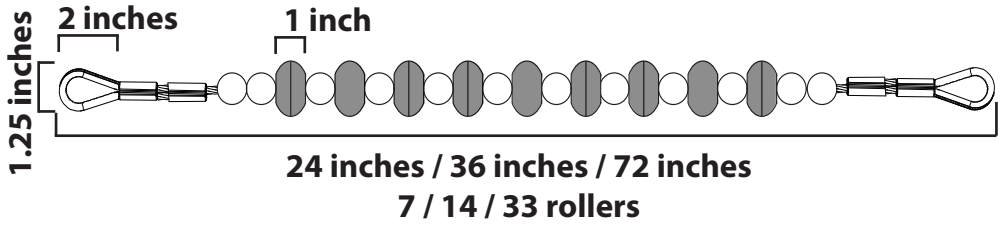

PERFORMANCE:

Minimum Breaking Strength (MBS):

5000-lbf (22kN)

DIMENSIONS:

Length: 2 feet, 3 feet or 6 feet

REGULATORY COMPLIANCE:

ANSI Z359.18 Type A, ANSI Z359.7(19),
OSHA 29 CFR 1926.502, OSHA 29
CFR 1910.140

COMPONENT MATERIALS:

Aircraft Cable
Polyurethane
Zinc Plated Steel
Zinc Plated Copper

CONFIGURATIONS:

*Note: Not recommended for use with pipe diameters under 3 inches.
Do not loop around sharp edges or small diameter structural members that could lessen structural integrity of the anchorage connector.

BASKET ANCHOR

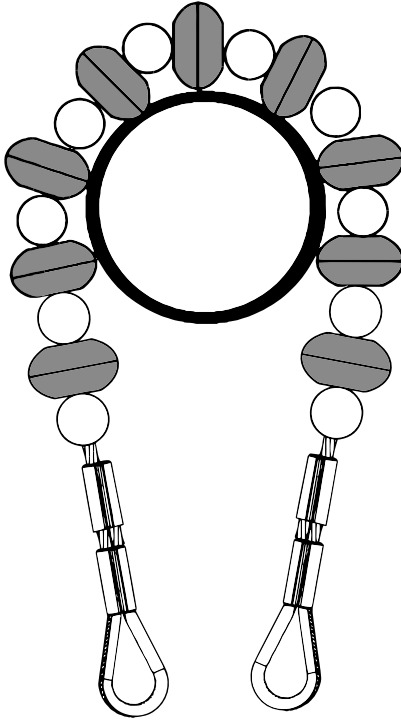

VERTICAL ANCHOR

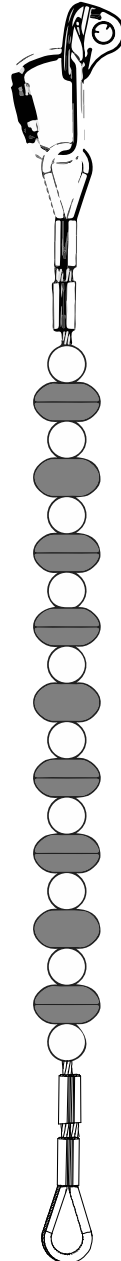

⚠ WARNING

Only make compatible connections!
Due to the risk of improper loading,
roller sling terminations must not be
connected to each other by a single
snaphook. Only OSHA compatible
connections, such as a Y-lanyard or
Werner A100303 , are permitted.

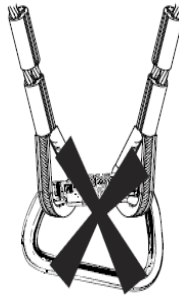

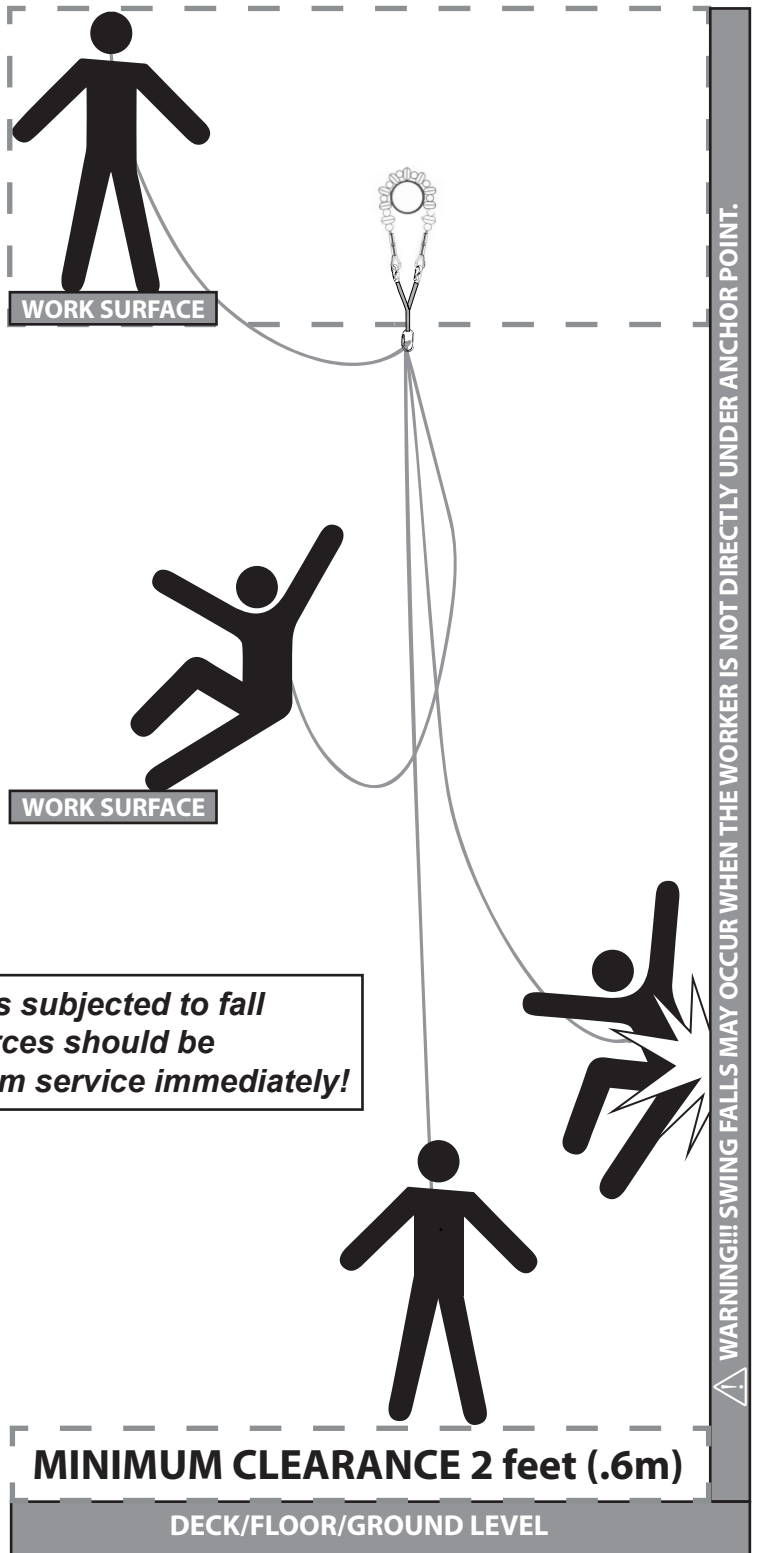

**All products subjected to fall arresting forces should be removed from service immediately!*

MINIMUM CLEARANCE 2 feet (.6m)

DECK/FLOOR/GROUND LEVEL

WARNING!!! SWING FALLS MAY OCCUR WHEN THE WORKER IS NOT DIRECTLY UNDER ANCHOR POINT.

MAINTENANCE, CLEANING AND STORAGE

Cleaning periodically will prolong the life and proper functioning of the product. The frequency of cleaning should be determined by inspection and by severity of the environment. Clean with compressed air and/or a stiff brush using plain water or a mild soap and water solution. Do not use any corrosive chemicals that could damage the product. Wipe all surfaces with a clean, dry cloth and hang to dry, or use compressed air. When not in use, store anchorage connectors in a cool, dry, clean environment, out of direct sunlight and free of corrosive or other degrading elements.

INSPECTION AND MAINTENANCE LOG

MODEL NUMBER: _____

DATE OF MANUFACTURE: _____

Date	Part Number	Comments	Inspector Name

Inspection:

Official periodic inspection must be performed at least annually. The inspection must be performed by a competent or qualified person other than the intended user. If severe weather or conditions exist then inspections must be carried out more frequently. All inspection results must be logged in the space provided above.

- 1. Ensure all labeling is affixed to the unit.
- 2. Inspect anchoring system for signs of damage or wear.
- 3. Record inspection results in the space provided above.

***If inspection reveals any damage that could affect the strength or operation of the device, inadequate maintenance, or an unsafe condition, proper disposal is required. The anchorage connector must be rendered unusable and then properly discarded.**

Werner Co.
93 Werner Road
Greenville, PA 16125
1(888) 523-3371 / www.wernerco.com
P/N 124587-01 REV B 4/21