

- In addition to routine checks for each use, PPE should regularly undergo a detailed inspection by a competent person. Petzl recommends an inspection every 12 months and after any exceptional event in the life of the product.
 - PPE inspection should be conducted with the manufacturer's Instructions for Use.
- Download the instructions at PETZL.COM.



PULSE / COEUR PULSE



1. Known product history

Any PPE showing unexpected degradation should be quarantined, pending a detailed inspection.

The user should:

- Provide precise information on the usage conditions.
- Report any exceptional event regarding his/her PPE.

(Examples: fall or fall arrest, use or storage at extreme temperatures, modification outside manufacturer's facilities...).



2. Preliminary observations

Verify the presence and legibility of the serial number and the CE mark.

Note: the serial number code on our products is evolving. Two types of code will coexist. See below for details on each serial number code.

Code A:

00 000 AA 0000

Year of manufacture
Day of manufacture
Name of Inspector
Incrementation

Code B:

00 A 0000000 000

Year of manufacture
Month of manufacture
Batch number
Incrementation

Verify that the product lifespan has not been exceeded.

Compare with a new product to verify there are no modifications or missing parts.

Note: For the B coding, the month of manufacturing is indicated by a letter. A corresponds to January, B to February, C to March, and so on.

3. Inspecting the hanger

- Check the condition of the hanger (marks, deformation, cracks, corrosion...).

- Check the attachment hole: absence of deformation or of a sharp edge that could damage a sling threaded through the hanger.

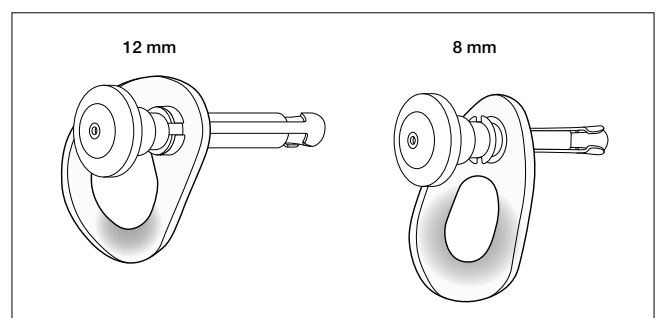
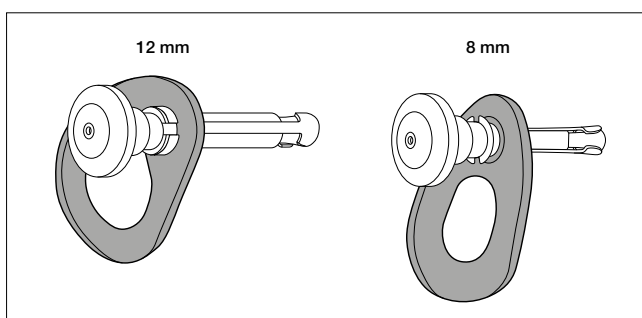

4. Inspecting the shaft and the moving wedge plates

- Check the condition of the wedge plates (marks, deformation, cracks, corrosion...). Beware of dirt or other contaminants accumulating under the wedge plates: clean if necessary.

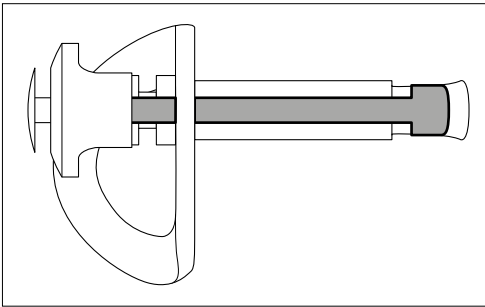

- Carefully check the condition of the wedge cone (marks, deformation, cracks, corrosion...).

- Check the condition of the shaft (marks, deformation, cracks, corrosion...).

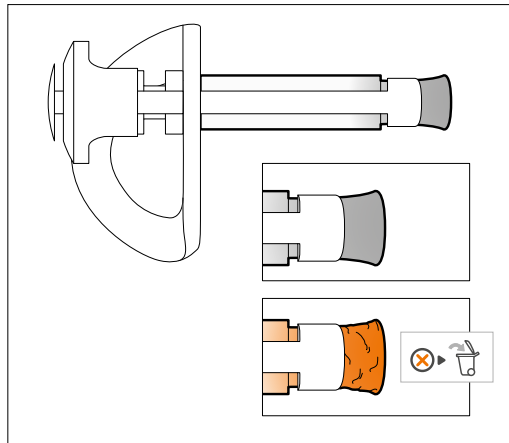
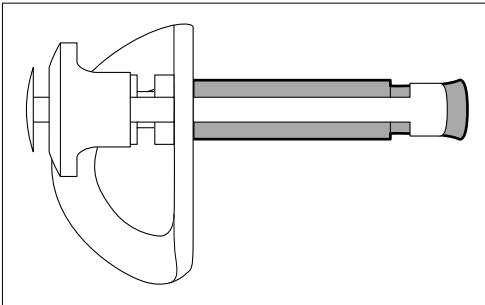

5. Inspecting the release plunger

- Check the condition of the plunger and its lock (marks, deformation, cracks, corrosion...).

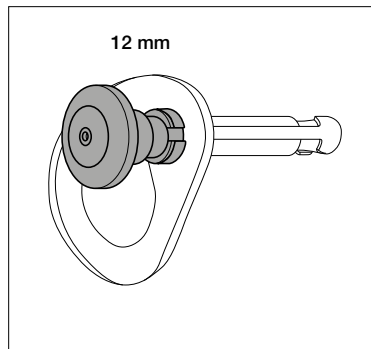

- Check the release function: pulling the plunger, check that the moving wedge plates slide properly. Check the effectiveness of the return spring when the plunger is released. Specifically check that the moving wedge plates slide smoothly and correctly over the wedge cone.

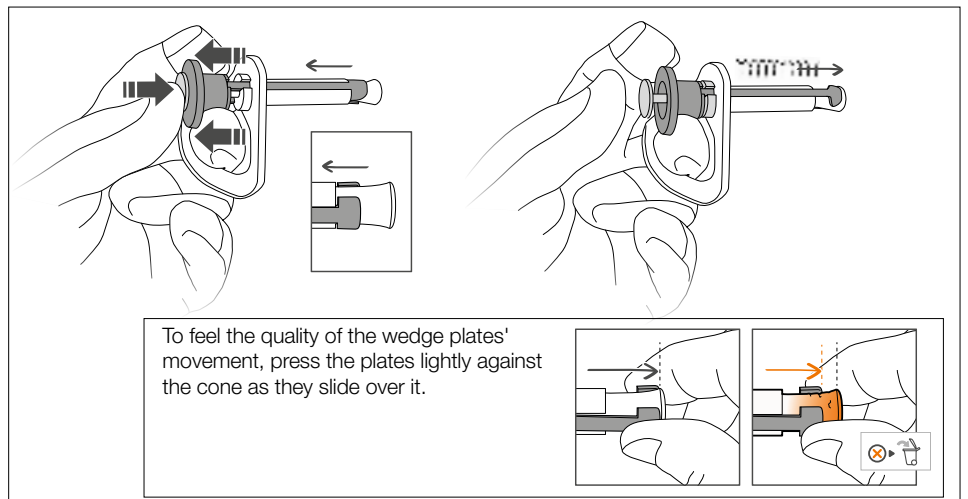

- Verify that the plunger locks.

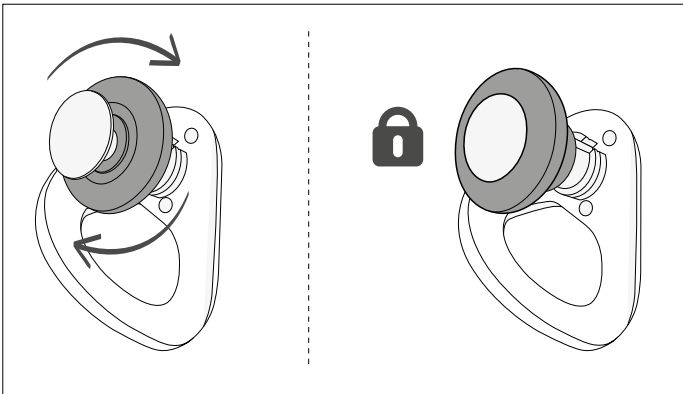

6. Inspecting the hanger/shaft connection

- Verify the presence and condition of the o-ring.

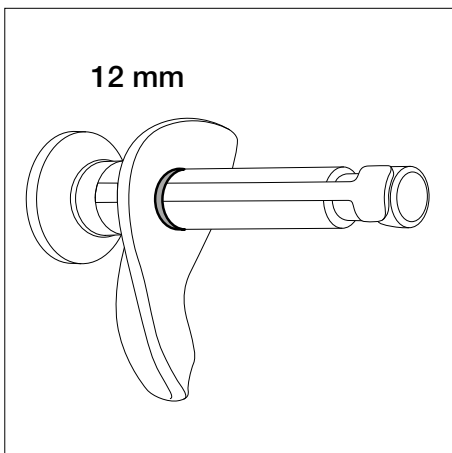

Appendix: Examples of common issues to look for during inspection

- Wedge plates separated from the cone



- Bent wedge plate



- Marked wedge cone



- Marked wedge cone



- Marked wedge cone



- Bent plunger



- Marked and deformed plunger



- Marked shaft, broken wedge plate

